

“ROTER FADEN” – DESIGN EDUCATION IN CONTEXT

Frank Mantwill

ABSTRACT

“Roter Faden” is the name of a new teaching concept at Helmut-Schmidt-University (HSU) in Hamburg. The name itself is a German saying which generally means “a main thread running through something”. This thread guides the students through the mechanical engineering program. It provides a better understanding how different courses contribute to coverage of a technical product. In the end the student should realize that all courses, both the basic disciplines and the application oriented ones are prerequisite for engineering practice. Especially those students who focus on design engineering learn more about interdependencies between technical disciplines. This is very important in engineering practice.

A technical product, which should be known by many of the students, stands in the focus of “Roter Faden”. When selecting a suitable product it has to be ensured that at least one example from each course of the mechanical engineering program can be applied. Finally complexity should be as low as possible to keep the main focus clear.

In cooperation with a local company a pedestrian forklift truck was selected as an appropriate product for “Roter Faden”. “Roter Faden” starts with a visit to the plant in the first semester. After a general introduction of the main idea of the “Roter Faden” heads of several departments present the company, the product and its customers. Thereafter specialists from marketing, development, production and quality management explain their topics while walking through the plant.

Each professor uses suitable examples of the fork lift truck to apply the idea of “Roter Faden” in their course. Samples and technical information are provided by the company to make it more vital.

Keywords: education in context, leitmotif, industrial relation, mechanical engineering

1 INTRODUCTION

Globalisation has caused many changes. One of the gravest changes in this context concerns competition which has become harder over the years and indeed will continue to become harder in the future. Innovative products and their economic production are most often cited in order to ensure competition advantages. Because there are favourable possibilities for economic production in global competition, leading industrial nations concentrate with high wages on leading product and process innovation.

The proclamation of the scientific community is also based on these basic conditions. The initial point of this scientific community is the excellent qualification of the employees of each company. This qualification results from training which is to be seen as the beginning of life-long learning.

The importance of a comprehensive and challenging training at school and in further education cannot be denied.

Particularly in further education there is an area of conflict between continuously expanding knowledge which has to be brought across and the economical presentation of this knowledge. Particularly the latter is being encouraged due to the Bologna-Process initiated in Europe [1]. In the future, Bachelor and Master Degrees course descriptions necessary for accrediting will certainly lead to more transparency of studies in connection with the evaluation of lectures. The quality of knowledge presentation however remains untouched. On the contrary, this re-organisation of studies will on paper lead to cutbacks in the specified range of knowledge as in the future the amount of subject matter in standard training will be reduced. On the one hand this offers economic advantages. On the other it will offer, at the cost of specialised training, subjects which are to emphasise soft skills so that graduates are better prepared for the working environment.

Discussions with representatives of industry show that there is also great interest in this expanded training. However they also take for granted the widely highly regarded general basic knowledge that is the basic goal of the current engineering program in Germany.

How can the contradiction of the increasing requirements of the scientific community and of economical training be eliminated?

2 NEW APPROACHES TO TEACHING

The typical university course today and after the change to Bachelor and Master Degrees consists of fundamental principles and application. In the fundamental principles part maths, mechanics and similar such typical subjects are taught which form a basis for later applications. Often in the first terms endless principles rain down on the students without any obvious connection to current or future applications. Thus the student is forced to cram all of these subjects without knowing why. A good example of this is the spring which is treated in the lectures on Machine Elements, Mechanics, Material Science etc. but always separately and independently. Thus the student only discovers the similarities of the spring concerning Mechanics and Machine Elements more or less accidentally. Particularly these inter-disciplinary connections offer possibilities for improved teaching and thus a more effective way of imparting knowledge [2].

There is a whole range of approaches to improve teaching at university level. Many follow the same goal as the "Roter Faden", i.e. using concrete projects to bring students together, to teach soft skills such as project management and team work and to present technical connections more graphically. For example at the TU Darmstadt there is a project in their first term in which the students' curiosity about the technical course is aroused [3]. Later in the course the students have the chance to take part in competitions in order to practice teamwork and creativity. The use of projects within courses is relatively widespread. The students learn project-orientated work on the basis of the knowledge gleaned from the course. In Munich there is also coaching for the project team in order to particularly develop soft-skills. Other universities also offer information events at the beginning of a course in order to prepare students for the following studies, for example TU Hamburg-Harburg, where the professors involved present a component for an aeroplane as part of a series of lectures by different speakers.

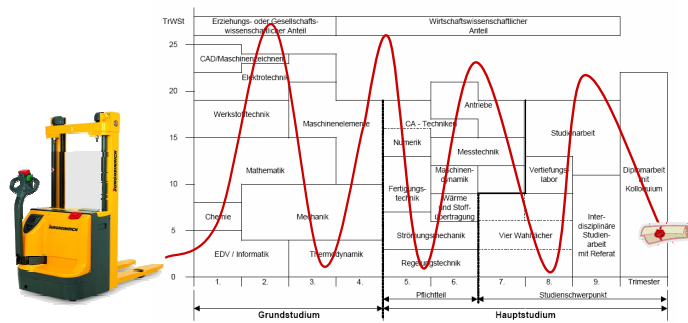

Figure 1: "Roter Faden" as a thread of the course mechanical engineering

The "Roter Faden" concept follows a similar course and was developed in 2004 and first put into practice in October 2005 at the Helmut-Schmidt-University in Hamburg. In contrast to the above examples, the "Roter Faden" does not restrict itself to a certain part of the course. During every single teaching element the student should be shown how that particular subject is necessary for engineering understanding of a technical product and how this understanding can be applied.

The basic idea of "Roter Faden" is to define a technical product as a leitmotif throughout the course (Figure 1). This does not place the combination of the various subjects primarily in focus. The linking of the subjects by the chosen technical product is to have the result that also the specific basic knowledge can be imparted more graphically. Within this context, theory and application should be imparted both per discipline and inter-disciplinarily.

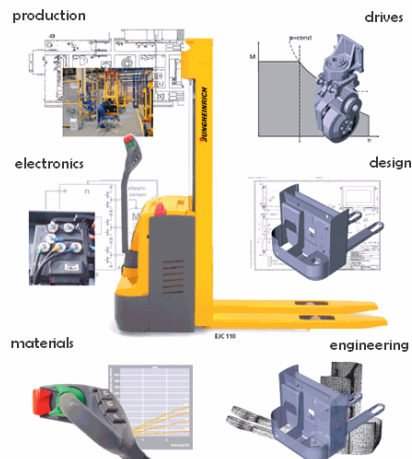

Figure 2: Pedestrian fork lift truck as leitmotif of "Roter Faden"

The concentration on a technical product is not to lead to a restricted training. The specified theme of the course remains the focus within the separate subjects. The leitmotif of the "Roter Faden" is only applied when the content of the lecture or coursework is suitable and aids understanding. The requirements of a suitable technical product for the leitmotif result from the requirements of the course. All subjects on the course should be found in the technical product, it should be well known to most

students and its complexity should not be overwhelming. A product should not be chosen that has attractive technology but is so complex that it is more likely to confuse than impart knowledge. It must always be taken into account that "Roter Faden" starts in the first term and thus cannot assume great technological understanding.

The technical product should also be well documented. The speakers on each subject must be persuaded to allow access to their lecture notes in order to prepare relevant examples. Against this background the idea was developed to choose the leitmotif in cooperation with a company which developed, produced and markets it.

The Helmut-Schmidt-University chose the company Jungheinrich AG in Norderstedt near Hamburg as cooperation partner for the "Roter Faden". The pedestrian forklift truck EJC 110 filled the above requirements of a leitmotif (Figure 2). Jungheinrich also offers all teaching staff support in the form of documentation and demonstration components which can be used for a meaningful presentation of the product within the context of lectures and coursework. During the module Machine Elements for example, the forklift guidance, the welding construction of the fork lift itself and the brakes are lecture topics. Students also have the opportunity to analyse and discuss the gearbox. In the Mechanics module the statics can be practised, and in the Mathematical module stability can be calculated.

3 APPLICATION OF THE "ROTER FADEN"

The "Roter Faden" begins with an excursion to Jungheinrich during the first term. The students are just beginning to orientate themselves and should be introduced to the leitmotif at an early stage. The aim of this excursion is to familiarise the student with the technical product and a business context. Thus the students experience the company, the pedestrian fork lift truck, its development, its production, its marketing and the customers at first hand. The students already receive their first impression of business processes and the connections between the different disciplines during this excursion. Especially with the pedestrian fork lift truck chosen, the interaction between electrics and ME-Mechanics is very close and aimed directly at the needs of the consumer.



Figure 3: Excursion in the beginning of the course [Jungheinrich]

During the rest of the course the student is repeatedly presented with examples referring to the leitmotif during lectures and coursework. Together with the impression left by the excursion he is then in a position to understand the imparted knowledge in the relevant context and to process it more successfully.

Two courses have been started with the "Roter Faden". The responses of the students of the first course confirm the support provided by the content of the "Roter Faden". Particularly in the module Machine Elements an improvement in the grades of the participants can be noted.

The students themselves also had suggestions for improvement. These mainly concerned the basic concept of the "Roter Faden". The excursion takes place at the beginning of the course and at this point the students learn a great amount about the development of the product und industrial processes. Many wished for an excursion at a later point in the course in order to better understand what they had seen. An improvement would thus be a second excursion later on in the course.

Within the context of a Kick-off-Event Jungheinrich and the professors of the Mechanical Engineering Department undertook the planning of the "Roter Faden". The professors familiarised themselves with the company, its processes and the technical product in order to provide approaches for their lectures. Jungheinrich was able to participate in improving training and could also present itself to the students. In the meantime other seats of further education have shown an interest in "Roter Faden". A further unforeseen use could also be experienced during the application. Whilst considering the technical product together the professors also discussed the content of their lectures and received suggestions on how to improve the coordination of individual lectures. This is certainly also in the interest of students and the very basic goal of the "Roter Faden".

4 SUMMARY AND PROSPECT

The "Roter Faden" began in October 2005. The students were introduced to a technical product and the company that produced it. During the course the product was referred to at relevant points during lectures and coursework in order to provide the student with a subject-orientated reference to a real object. This in turn emphasized the diversity of engineering thought processes and brought home the logical connections between individual modules of the Mechanical Engineering course.

The second set of students began their course with this program. As well as organisational improvements to the excursion the next important task is to systematically collate and evaluate the experiences of the students and the teaching staff. This will be possible in 2008.

REFERENCES

- [1] Eckardt, P. Der Bologna-Prozess. Entstehung, Strukturen und Ziele der europäischen Hochschulreformpolitik, Books on Demand GmbH, 2005
- [2] Dietz, P. Concurrent Engineering - Folgen für die Ausbildung *IMW Institutsmittellung Nr. 20*, 1995, 31-42.
- [3] Hampe, M. Einführung in den Maschinenbau – Ein Projektkurs für Erstsemester. *TUD Schriftenreihe Wissenschaft und Technik, Band 82*, 2001.

Acknowledgements

The author gratefully acknowledges Jungheinrich AG for their great involvement.

Prof. Dr.-Ing. Frank MANTWILL
Helmut-Schmidt-University Hamburg
MRP
Holstenhofweg 85
D-22043 Hamburg, GERMANY
Frank.mantwill@hsu-hh.de
+49 (0) 40-6541-2730